

STEEL PIPE FLANGE

(PN series) European system
HG/T20592-2009(HG 20592-1997)

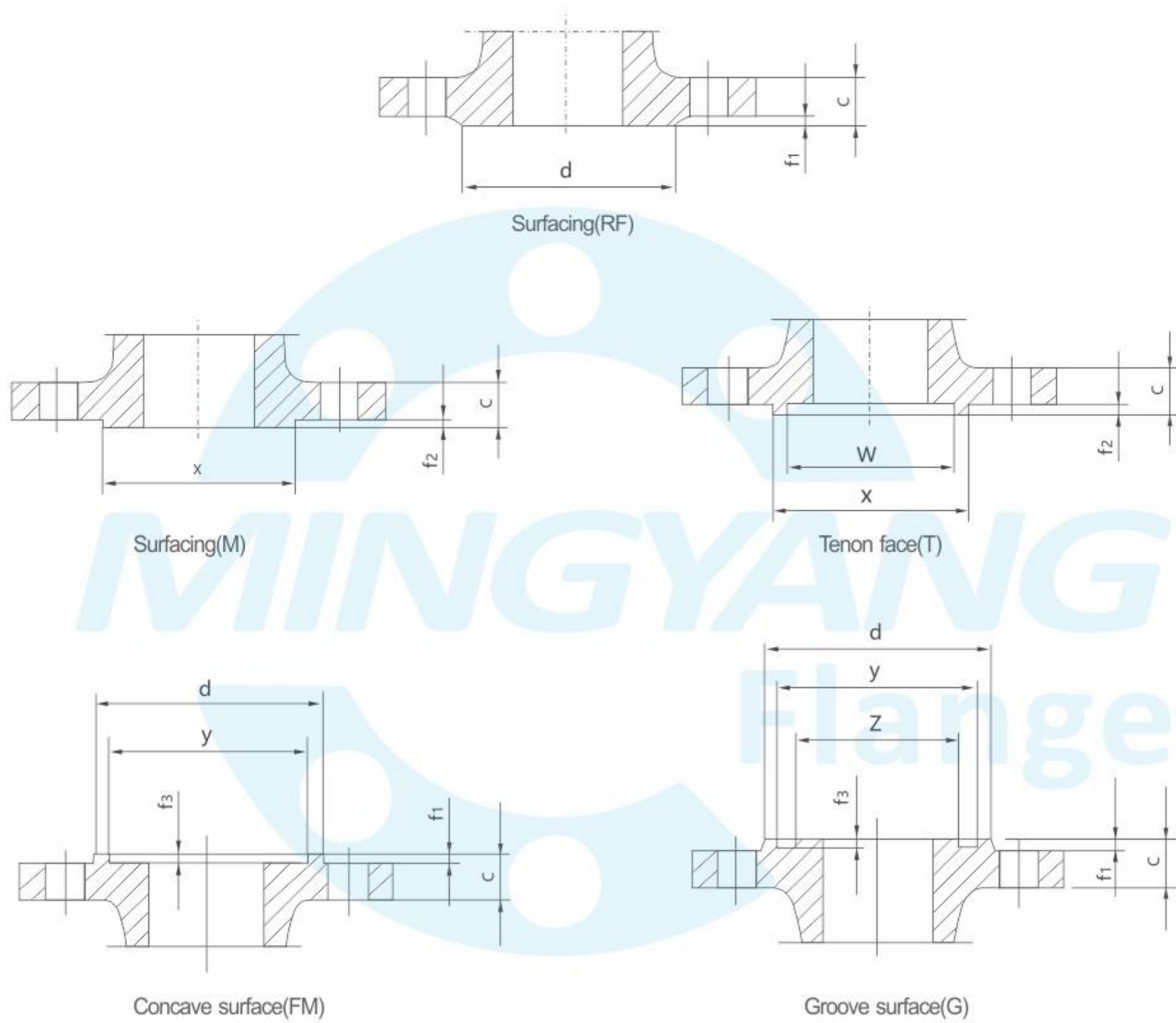

Size of sealing surface of protruding surface, concave surface/convex surface, tenon surface/groove surface

SEALING SURFACE SIZE (Protruded surface, concave surface, convex surface, tenon surface, groove surface)

DN	d						f1	f2	f3	W	X	Y	Z
	PN												
	2.5	6	10	16	25	≥40							
10	35	35	40	40	40	40	2	4.5	4.0	24	34	35	23
15	40	40	45	45	45	45	2	4.5	4.0	29	39	40	28
20	50	50	58	58	58	58	2	4.5	4.0	36	50	51	35
25	60	60	68	68	68	68	2	4.5	4.0	43	57	58	42
32	70	70	78	78	78	78	2	4.5	4.0	51	65	66	50
40	80	80	88	88	88	88	2	4.5	4.0	61	75	76	60
50	90	90	102	102	102	102	2	4.5	4.0	73	87	88	72
65	110	110	122	122	122	122	2	4.5	4.0	95	109	110	94
80	128	128	138	138	138	138	2	4.5	4.0	106	120	121	105
100	148	148	158	158	162	162	2	5.0	4.5	129	149	150	128
125	178	178	188	188	188	188	2	5.0	4.5	155	175	176	154
150	202	202	212	212	218	218	2	5.0	4.5	183	203	204	182
200	258	258	268	268	278	285	2	5.0	4.5	239	259	260	238
250	312	312	320	320	335	345	2	5.0	4.5	292	312	313	291
300	365	365	370	378	395	410	2	5.0	4.5	343	363	364	342
350	415	415	430	428	450	465	2	5.5	5.0	395	421	422	394
400	465	465	482	490	505	535	2	5.5	5.0	447	473	474	466
450	520	520	532	550	555	560	2	5.5	5.0	497	523	524	496
500	570	570	585	610	615	615	2	5.5	5.0	549	575	576	548
600	670	670	685	725	720	735	2	5.5	5.0	649	675	676	648
700	775	775	800	795	820	-	2	-	-	-	-	-	-
800	880	880	905	900	930	-	2	-	-	-	-	-	-
900	980	980	1005	1000	1030	-	2	-	-	-	-	-	-
1000	1080	1080	1110	1115	1140	-	2	-	-	-	-	-	-
1200	1280	1295	1330	1330	1350	-	2	-	-	-	-	-	-
1400	1480	1510	1535	1530	-	-	2	-	-	-	-	-	-
1500	1690	1710	1760	1750	-	-	2	-	-	-	-	-	-
1800	1890	1920	1960	1950	-	-	2	-	-	-	-	-	-
2000	2090	2125	2170	2150	-	-	2	-	-	-	-	-	-

HG/T20593-2009(PL)

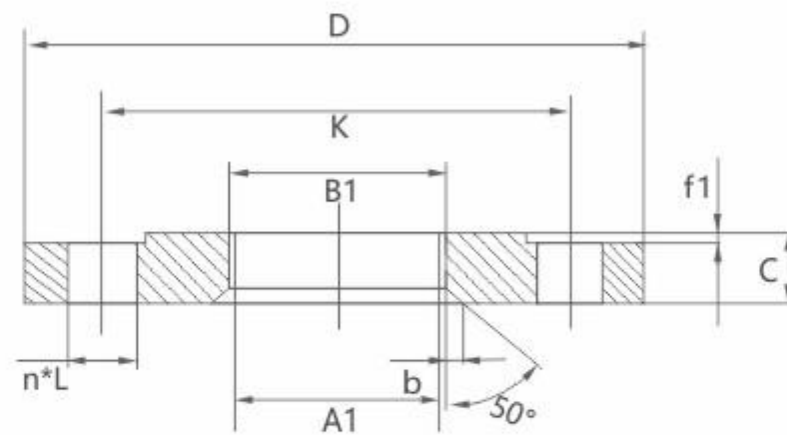
PLATE FLAT WELDED STEEL PIPE FLANGE

PN2.5

size	Steel pipe outer diameter A1		Connection size					Flange thickness C	Flange bore B1	
	DN	A	B	D	K	L	n		Th	A
10	17.2	14	75	50	11	4	M10	12	18	15
15	21.3	18	80	55	11	4	M10	12	22.5	19
20	26.9	25	90	65	11	4	M10	14	27.5	26
25	33.7	32	100	75	11	4	M10	14	34.5	33
32	42.4	38	120	90	14	4	M12	16	43.5	39
40	48.3	45	130	100	14	4	M12	16	49.5	46
50	60.3	57	140	110	14	4	M12	16	61.5	59
65	76.1	76	160	130	14	4	M12	16	77.5	78
80	88.9	89	190	150	18	4	M16	18	90.5	91
100	114.3	108	210	170	18	4	M16	18	116	110
125	139.7	133	240	200	18	8	M16	20	143.5	135
150	168.3	159	265	225	18	8	M16	20	170.5	161
200	219.1	219	320	280	18	8	M16	22	221.5	222
250	273	273	375	335	18	12	M16	24	276.5	276
300	323.9	325	440	395	22	12	M20	24	328	328
350	355.6	377	490	445	22	12	M20	26	360	381
400	406.4	426	540	495	22	16	M20	28	411	430
450	457	480	595	550	22	16	M20	30	462	485
500	508	530	645	600	22	20	M20	30	513.5	535
600	610	630	755	705	26	20	M24	32	616.5	636
700	711	720	860	810	26	24	M24	36	715	724
800	813	820	975	920	30	24	M27	38	817	824
900	914	920	1075	1020	30	24	M27	40	918	924
1000	1016	1020	1175	1120	30	28	M27	42	1020	1024
1200	1219	1220	1375	1320	30	32	M27	44	1223	1224
1400	1422	1420	1575	1520	30	36	M27	48	1426	1424
1600	1626	1620	1790	1730	30	40	M27	51	1630	1624
1800	1829	1820	1990	1930	30	44	M27	54	1833	1824
2000	2032	2020	2190	2130	30	48	M27	58	2036	2024

HG/T20593-2009(PL)

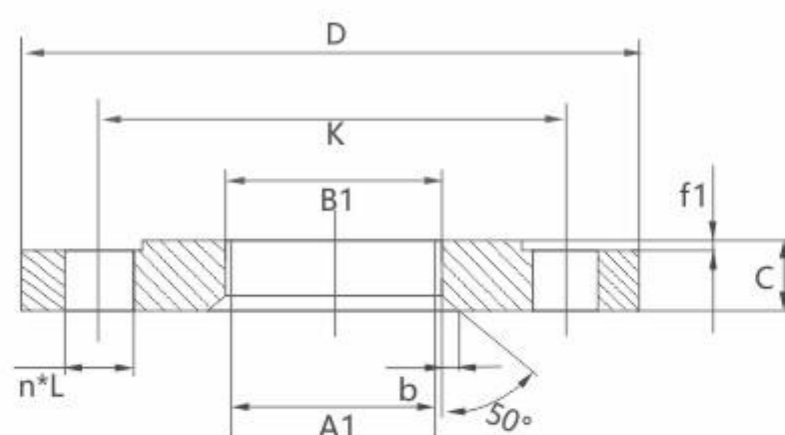
PLATE FLAT WELDED STEEL PIPE FLANGE



PN6

size	Steel pipe outer diameter A1		Connection size				Flange thickness	Flange bore B1		
	DN	A	B	D	K	L		n	Th	C
10	17.2	14	75	50	11	4	M10	12	18	15
15	21.3	18	80	55	11	4	M10	12	22.5	19
20	26.9	25	90	65	11	4	M10	14	27.5	26
25	33.7	32	100	75	11	4	M10	14	34.5	33
32	42.4	38	120	90	14	4	M12	16	43.5	39
40	48.3	45	130	100	14	4	M12	16	49.5	46
50	60.3	57	140	110	14	4	M12	16	61.5	59
65	76.1	76	160	130	14	4	M12	16	77.5	78
80	88.9	89	190	150	18	4	M16	18	90.5	91
100	114.3	108	210	170	18	4	M16	18	116	110
125	139.7	133	240	200	18	8	M16	20	143.5	135
150	168.3	159	265	225	18	8	M16	20	170.5	161
200	219.1	219	320	280	18	8	M16	22	221.5	222
250	273	273	375	335	18	12	M16	24	276.5	276
300	323.9	325	440	395	22	12	M20	24	328	328
350	355.6	377	490	445	22	12	M20	26	360	381
400	406.4	426	540	495	22	16	M20	28	411	430
450	457	480	595	550	22	16	M20	30	462	485
500	508	530	645	600	22	20	M20	30	513.5	535
600	610	630	755	705	26	20	M24	32	616.5	636

HG/T20593-2009(PL)

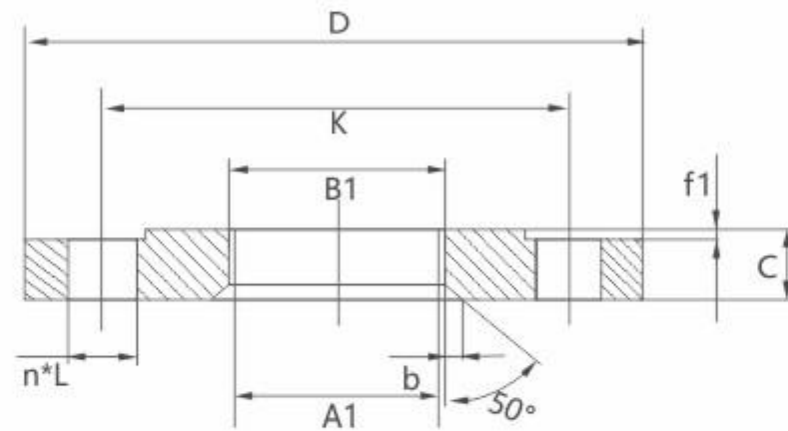
PLATE FLAT WELDED STEEL PIPE FLANGE

PN10

size	Steel pipe outer diameter A1		Connection size					Flange thickness C	Flange bore B1	
	DN	A	B	D	K	L	n		Th	A
10	17.2	14	90	60	14	4	M12	14	18	15
15	21.3	18	95	65	14	4	M12	14	22.5	19
20	26.9	25	105	75	14	4	M12	16	27.5	26
25	33.7	32	115	85	14	4	M12	16	34.5	33
32	42.4	38	140	100	18	4	M16	18	43.5	39
40	48.3	45	150	110	18	4	M16	18	49.5	46
50	60.3	57	165	125	18	4	M16	19	61.5	59
65	76.1	76	185	145	18	8	M16	20	77.5	78
80	88.9	89	200	160	18	8	M16	20	90.5	91
100	114.3	108	220	180	18	8	M16	22	116	110
125	139.7	133	250	210	18	8	M16	22	143.5	135
150	168.3	159	285	240	22	8	M20	24	170.5	161
200	219.1	219	340	295	22	8	M20	24	221.5	222
250	273	273	395	350	22	12	M20	26	276.5	276
300	323.9	325	445	400	22	12	M20	26	328	328
350	355.6	377	505	460	22	16	M20	28	360	381
400	406.4	426	565	515	26	16	M24	32	411	430
450	457	480	615	565	26	20	M24	36	462	485
500	508	530	670	620	26	20	M24	38	513.5	535
600	610	630	780	725	30	20	M27	42	616.5	636

HG/T20593-2009(PL)

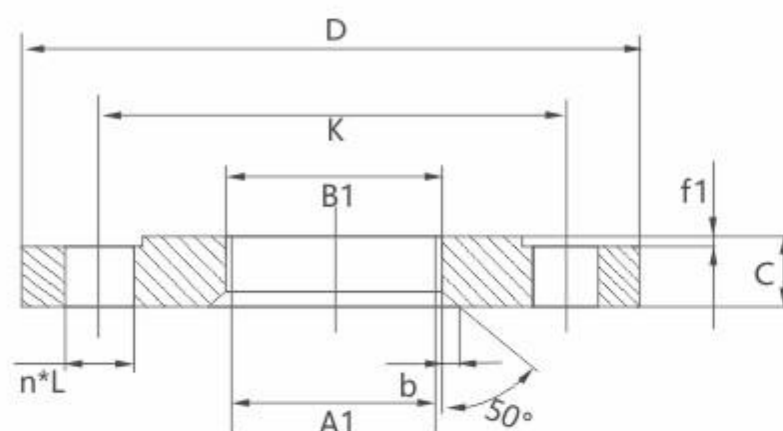
PLATE FLAT WELDED STEEL PIPE FLANGE



PN16

size	Steel pipe outer diameter A1		Connection size					Flange thickness C	Flange bore B1		Slope width b
	DN	A	B	D	K	L	n		Th	A	
10	17.2	14	90	60	14	4	M12	14	18	15	4
15	21.3	18	95	65	14	4	M12	14	22.5	19	4
20	26.9	25	105	75	14	4	M12	16	27.5	26	4
25	33.7	32	115	85	14	4	M12	16	34.5	33	5
32	42.4	38	140	100	18	4	M16	18	43.5	39	5
40	48.3	45	150	110	18	4	M16	18	49.5	46	5
50	60.3	57	165	125	18	4	M16	19	61.5	59	5
65	76.1	76	185	145	18	8	M16	20	77.5	78	6
80	88.9	89	200	160	18	8	M16	20	90.5	91	6
100	114.3	108	220	180	18	8	M16	22	116	110	6
125	139.7	133	250	210	18	8	M16	22	143.5	135	6
150	168.3	159	285	240	22	8	M20	24	170.5	161	6
200	219.1	219	340	295	22	12	M20	26	221.5	222	8
250	273	273	405	355	26	12	M24	29	276.5	276	10
300	323.9	325	460	410	26	12	M24	32	328	328	11
350	355.6	377	520	470	26	16	M24	35	360	381	12
400	406.4	426	580	525	30	16	M27	38	411	430	12
450	457	480	640	585	30	20	M27	42	462	485	12
500	508	530	715	650	33	20	M30	46	513.5	535	12
600	610	630	840	770	36	20	M33	52	616.5	636	12

HG/T20593-2009(PL)

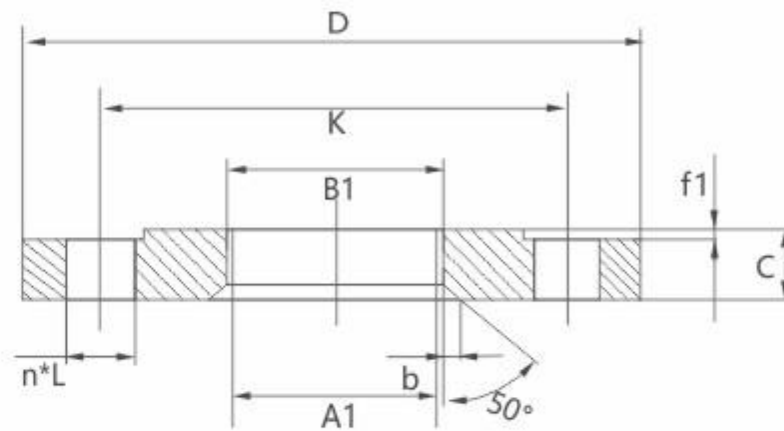
PLATE FLAT WELDED STEEL PIPE FLANGE

PN25

size	Steel pipe outer diameter A1		Connection size					Flange thickness	Flange bore B1		Slope width
	DN	A	B	D	K	L	n		Th	C	
10	17.2	14	90	60	14	4	M12	14	18	15	4
15	21.3	18	95	65	14	4	M12	14	22.5	19	4
20	26.9	25	105	75	14	4	M12	16	27.5	26	4
25	33.7	32	115	85	14	4	M12	16	34.5	33	5
32	42.4	38	140	100	18	4	M16	18	43.5	39	5
40	48.3	45	150	110	18	4	M16	18	49.5	46	5
50	60.3	57	165	125	18	4	M16	20	61.5	59	5
65	76.1	76	185	145	18	8	M16	22	77.5	78	6
80	88.9	89	200	160	18	8	M16	24	90.5	91	6
100	114.3	108	235	190	22	8	M20	26	116	110	6
125	139.7	133	270	220	26	8	M24	28	143.5	135	6
150	168.3	159	300	250	26	8	M24	30	170.5	161	6
200	219.1	219	360	310	26	12	M24	32	221.5	222	8
250	273	273	425	370	30	12	M27	35	276.5	276	10
300	323.9	325	485	430	30	16	M27	38	328	328	11
350	355.6	377	555	490	33	16	M30	42	360	381	12
400	406.4	426	620	550	36	16	M33	46	411	430	12
450	457	480	670	600	36	20	M33	50	462	485	12
500	508	530	730	660	36	20	M33	56	513.5	535	12
600	610	630	845	770	39	20	M36X3	68	616.5	636	12

HG/T20593-2009(PL)

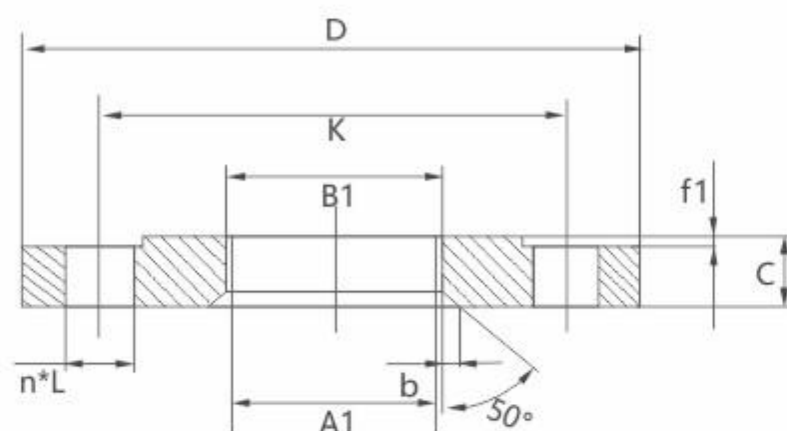
PLATE FLAT WELDED STEEL PIPE FLANGE



PN40

size	Steel pipe outer diameter A1		Connection size					Flange thickness C	Flange bore B1		Slope width b
	DN	A	B	D	K	L	n		Th	A	
10	17.2	14	90	60	14	4	M12	14	18	15	4
15	21.3	18	95	65	14	4	M12	14	22.5	19	4
20	26.9	25	105	75	14	4	M12	16	27.5	26	4
25	33.7	32	115	85	14	4	M12	16	34.5	33	5
32	42.4	38	140	100	18	4	M16	18	43.5	39	5
40	48.3	45	150	110	18	4	M16	18	49.5	46	5
50	60.3	57	165	125	18	4	M16	20	61.5	59	5
65	76.1	76	185	145	18	8	M16	22	77.5	78	6
80	88.9	89	200	160	18	8	M16	24	90.5	91	6
100	114.3	108	235	190	22	8	M20	26	116	110	6
125	139.7	133	270	220	26	8	M24	28	143.5	135	6
150	168.3	159	300	250	26	8	M24	30	170.5	161	6
200	219.1	219	375	320	30	12	M27	36	221.5	222	8
250	273	273	450	385	33	12	M30	42	276.5	276	10
300	323.9	325	515	450	33	16	M30	48	328	328	11
350	355.6	377	580	510	36	16	M33	54	360	381	12
400	406.4	426	660	585	39	16	M36X3	60	411	430	12
450	457	480	685	610	39	20	M36X3	66	462	485	12
500	508	530	755	670	42	20	M39X3	72	513.5	535	12
600	610	630	890	795	48	20	M45X3	84	616.5	636	12

HG/T20594-2009(SO)

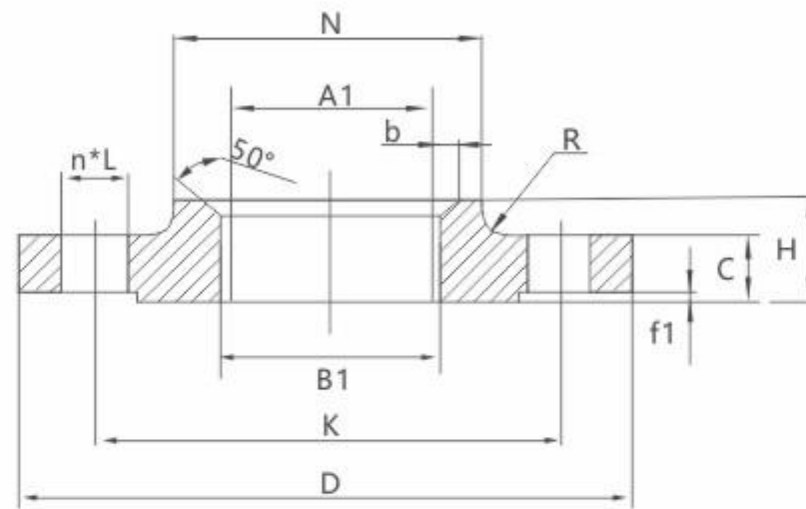
FLAT WELDED STEEL PIPE FLANGE WITH NECK

PN6

size	Steel pipe outer diameter A1		Connection size					Flange thickness	Flange bore B1		Flange neck N			Slope width
	DN	A	B	D	K	L	n		Th	C	A	B	A	
10	17.2	14	75	50	11	4	M10	12	18	15	25	25	4	20
15	21.3	18	80	55	11	4	M10	12	22.5	19	30	30	4	20
20	26.9	25	90	65	11	4	M10	14	27.5	26	40	40	4	24
25	33.7	32	100	75	11	4	M10	14	34.5	33	50	50	4	24
32	42.4	38	120	90	14	4	M12	14	43.5	39	60	60	6	26
40	48.3	45	130	100	14	4	M12	14	49.5	46	70	70	6	26
50	60.3	57	140	110	14	4	M12	14	61.5	59	80	80	6	28
65	76.1	76	160	130	14	4	M12	14	77.5	78	100	100	6	32
80	88.9	89	190	150	18	4	M16	16	90.5	91	110	110	8	34
100	114.3	108	210	170	18	4	M16	16	116	110	130	130	8	40
125	139.7	133	240	200	18	8	M16	18	143.5	135	160	160	8	44
150	168.3	159	265	225	18	8	M16	18	170.5	161	185	185	10	44
200	219.1	219	320	280	18	8	M16	20	221.5	222	240	240	10	44
250	273	273	375	335	18	12	M16	22	276.5	276	295	295	12	44
300	323.9	325	440	395	22	12	M20	22	328	328	355	355	12	44

HG/T20594-2009(SO)

FLAT WELDED STEEL PIPE FLANGE WITH NECK

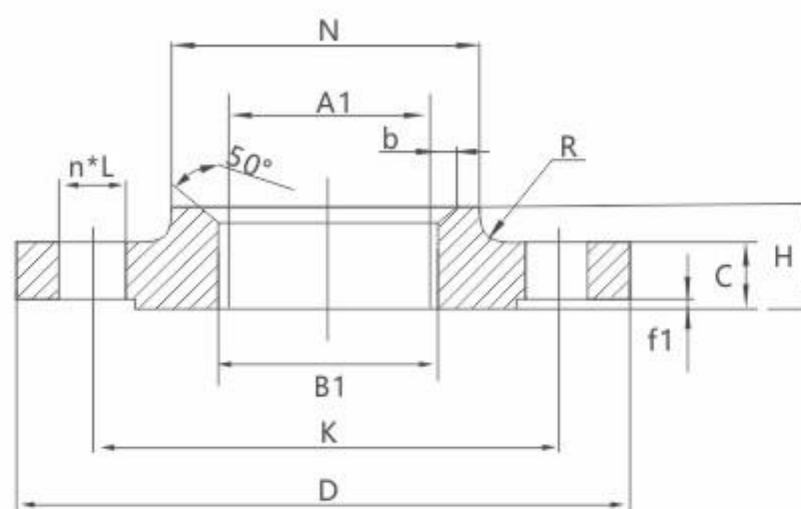

PN 10

size	Steel pipe outer diameter A1		Connection size					Flange thickness	Flange bore B1		Flange neck N			Slope width
	DN	A	B	D	K	L	n		Th	C	A	B	A	
10	17.2	14	90	60	14	4	M12	16	18	15	30	30	4	22
15	21.3	18	95	65	14	4	M12	16	22.5	19	35	35	4	22
20	26.9	25	105	75	14	4	M12	18	27.5	26	45	45	4	26
25	33.7	32	115	85	14	4	M12	18	34.5	33	52	52	4	28
32	42.4	38	140	100	18	4	M16	18	43.5	39	60	60	6	30
40	48.3	45	150	110	18	4	M16	18	49.5	46	70	70	6	32
50	60.3	57	165	125	18	4	M16	18	61.5	59	84	84	6	28
65	76.1	76	185	145	18	8	M16	18	77.5	78	104	104	6	32
80	88.9	89	200	160	18	8	M16	20	90.5	91	118	118	6	34
100	114.3	108	220	180	18	8	M16	20	116	110	140	140	8	40
125	139.7	133	250	210	18	8	M16	22	143.5	135	168	168	8	44
150	168.3	159	285	240	22	8	M20	22	170.5	161	195	195	10	44
200	219.1	219	340	295	22	8	M20	24	221.5	222	246	246	10	44
250	273	273	395	350	22	12	M20	26	276.5	276	298	298	12	46
300	323.9	325	445	400	22	12	M20	26	328	328	350	350	12	46
350	355.6	377	505	460	22	16	M20	26	360	381	400	412	12	53
400	406.4	426	565	515	26	16	M24	26	411	430	456	475	12	57
450	457	480	615	565	26	20	M24	28	462	485	502	525	12	63
500	508	530	670	620	26	20	M24	28	513.5	535	559	581	12	67
600	610	630	780	725	30	20	M27	28	516.5	636	658	678	12	75

HG/T20594-2009(SO)

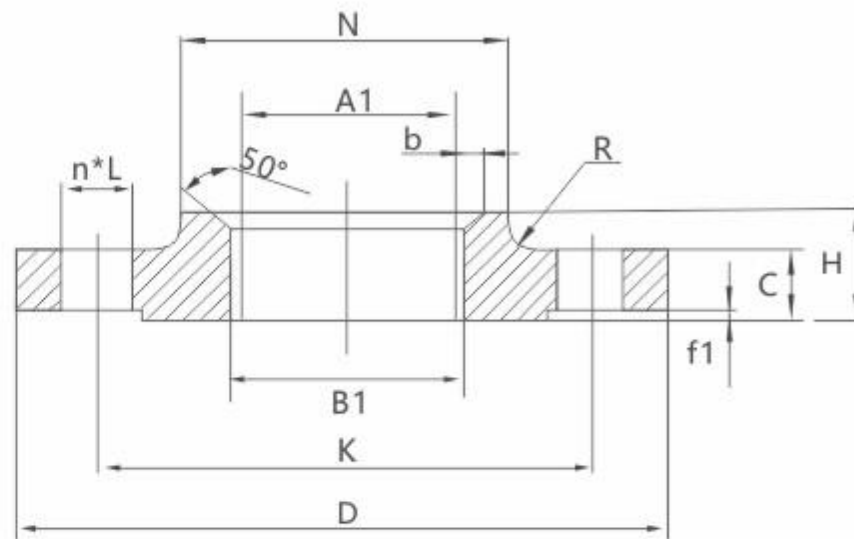
FLAT WELDED STEEL PIPE FLANGE WITH NECK

PN16

size	Steel pipe outer diameter A1		Connection size					Flange thickness C	Flange bore B1		Flange neck N			Flange height H	Slope width b
	DN	A	B	D	K	L	n		Th	A	B	A	B		
10	17.2	14	90	60	14	4	M12	16	18	15	30	30	4	22	4
15	21.3	18	95	65	14	4	M12	16	22.5	19	35	35	4	22	4
20	26.9	25	105	75	14	4	M12	18	27.5	26	45	45	4	26	4
25	33.7	32	115	85	14	4	M12	18	34.5	33	52	52	4	28	5
32	42.4	38	140	100	18	4	M16	18	43.5	39	60	60	6	30	5
40	48.3	45	150	110	18	4	M16	18	49.5	46	70	70	6	32	5
50	60.3	57	165	125	18	4	M16	18	61.5	59	84	84	5	28	5
65	76.1	76	185	145	18	8	M16	18	77.5	78	104	104	6	32	6
80	88.9	89	200	160	18	8	M16	20	90.5	91	118	118	6	34	6
100	114.3	108	220	180	18	8	M16	20	116	110	140	140	8	40	6
125	139.7	133	250	210	18	8	M16	22	143.5	135	168	168	8	44	6
150	168.3	159	285	240	22	8	M20	22	170.5	161	195	195	10	44	6
200	219.1	219	340	295	22	8	M20	24	221.5	222	246	246	10	44	8
250	273	273	405	355	26	12	M24	26	276.5	276	298	298	12	46	10
300	323.9	325	460	410	26	12	M24	28	328	328	350	350	12	46	11
350	355.6	377	520	470	26	16	M24	30	360	381	400	412	12	57	12
400	406.4	426	580	525	30	16	M27	32	411	430	456	475	12	63	12
450	457	480	640	585	30	20	M27	40	462	485	502	525	12	68	12
500	508	530	715	650	33	20	M30	44	513.5	535	559	581	12	73	12
600	610	630	840	770	36	20	M33	54	616.5	636	658	678	12	83	12

HG/T20594-2009(SO)

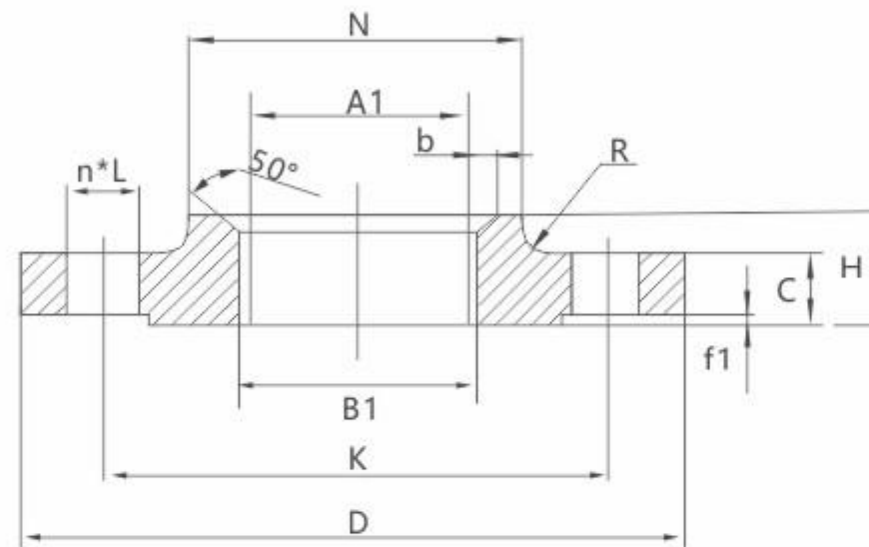
FLAT WELDED STEEL PIPE FLANGE WITH NECK



PN25

size	Steel pipe outer diameter A1		Connection size					Flange thickness	Flange bore B1		Flange neck N			Flange height	Slope width
	DN	A	B	D	K	L	n		Th	C	A	B	A		
10	17.2	14	90	60	14	4	M12	16	18	15	30	30	4	22	4
15	21.3	18	95	65	14	4	M12	16	22.5	19	35	35	4	22	4
20	26.9	25	105	75	14	4	M12	18	27.5	26	46	45	4	26	4
25	33.7	32	115	85	14	4	M12	18	34.5	33	52	52	4	28	5
32	42.4	38	140	100	18	4	M16	18	43.5	39	60	60	6	30	5
40	48.3	45	150	110	18	4	M16	18	49.5	46	70	70	6	32	5
50	60.3	57	165	125	18	4	M16	20	61.5	59	84	84	6	34	5
65	76.1	76	185	145	18	8	M16	22	77.5	78	104	104	6	38	6
80	88.9	89	200	160	18	8	M16	24	90.5	91	118	118	8	40	6
100	114.3	108	235	190	22	8	M20	24	116	110	145	145	8	44	6
125	139.7	133	270	220	26	8	M24	26	143.5	135	170	170	8	48	6
150	168.3	159	300	250	26	8	M24	28	170.5	161	200	200	10	52	6
200	219.1	219	360	310	26	12	M24	30	221.5	222	256	256	10	52	8
250	273	273	425	370	30	12	M27	32	276.5	276	310	310	12	60	10
300	323.9	325	485	430	30	16	M27	34	328	328	364	364	12	67	11
350	355.6	377	555	490	33	16	M30	38	360	381	418	430	12	72	12
400	406.4	426	620	550	36	16	M33	40	411	430	472	492	12	78	12
450	457	480	670	600	36	20	M33	46	462	485	520	542	12	84	12
500	508	530	730	660	36	20	M33	48	513.5	535	580	602	12	90	12
600	610	630	845	770	39	20	M36X3	58	616.5	636	684	704	12	100	12

HG/T20594-2009(SO)

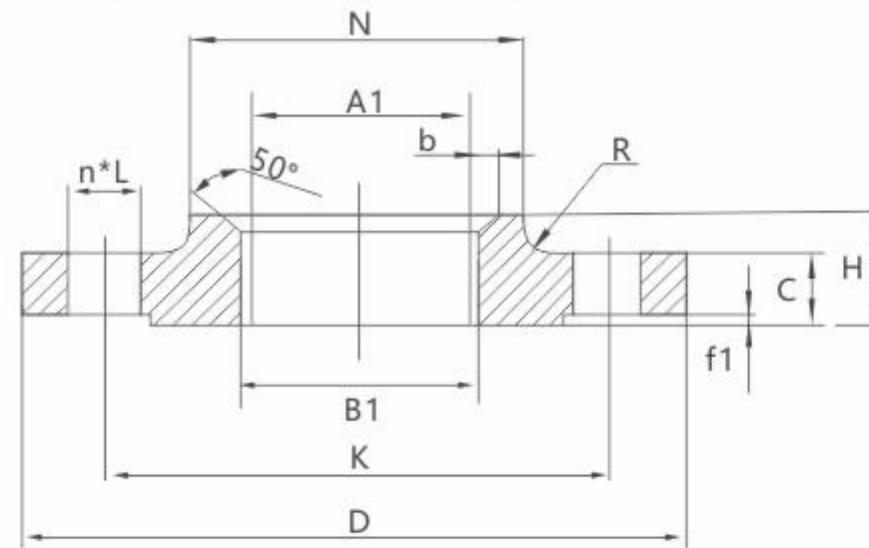
FLAT WELDED STEEL PIPE FLANGE WITH NECK

PN40

size	Steel pipe outer diameter A1		Connection size					Flange thickness C	Flange bore B1		Flange neck N			Flange height H	Slope width b
	DN	A	B	D	K	L	n		Th	A	B	A	B		
10	17.2	14	90	60	14	4	M12	16	18	15	30	30	4	22	4
15	21.3	18	95	65	14	4	M12	16	22.5	19	35	35	4	22	4
20	26.9	25	105	75	14	4	M12	18	27.5	26	45	45	4	26	4
25	33.7	32	115	85	14	4	M12	18	34.5	33	52	52	4	28	5
32	42.4	38	140	100	18	4	M16	18	43.5	39	60	60	6	30	5
40	48.3	45	150	110	18	4	M16	18	49.5	46	70	70	6	32	5
50	60.3	57	165	125	18	4	M16	20	61.5	59	84	84	6	34	5
65	76.1	76	185	145	18	8	M16	22	77.5	78	104	104	6	38	6
80	88.9	89	200	160	18	8	M16	24	90.5	91	118	118	8	40	6
100	114.3	108	235	190	22	8	M20	24	116	110	145	145	8	44	6
125	139.7	133	270	220	26	8	M24	26	143.5	135	170	170	8	48	7
150	168.3	159	300	250	26	8	M24	28	170.5	161	200	200	10	52	8
200	219.1	219	375	320	30	12	M27	34	221.5	222	260	260	10	52	10
250	273	273	450	385	33	12	M30	38	276.5	276	312	312	12	60	11
300	323.9	325	515	450	33	16	M30	42	328	328	380	380	12	67	12
350	355.6	377	580	510	36	16	M33	46	360	381	424	444	12	72	13
400	406.4	426	660	585	39	16	M36X3	50	411	430	478	518	12	78	14
450	457	480	685	610	39	20	M36X3	57	462	485	522	545	12	84	16
500	508	530	755	670	42	20	M39X3	57	513.5	535	576	598	12	90	17
600	610	630	890	795	48	20	M45X3	72	616.5	636	686	706	12	100	18

HG/T20595-2009 (WN)

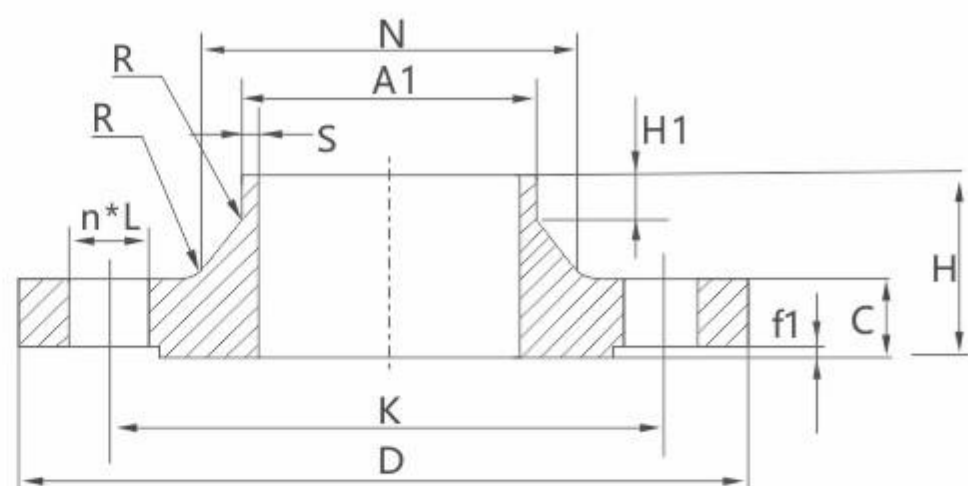
BUTT WELDING STEEL PIPE FLANGE WITH NECK



PN10

size	Steel pipe outer diameter A1		Connection size					Flange thickness	Flange neck				Flange height	
	DN	A	B	D	K	L	n		Th	C	A	B		S ≥
10	17.2	14	90	60	14	4	M12	16	28	28	1.8	6	4	35
15	21.3	18	95	65	14	4	M12	16	32	32	2.0	6	4	38
20	26.9	25	105	75	14	4	M12	18	40	40	2.3	6	4	40
25	33.7	32	115	85	14	4	M12	18	46	46	2.6	6	4	40
32	42.4	38	140	100	18	4	M16	18	56	56	2.6	6	6	42
40	48.3	45	150	110	18	4	M16	18	64	64	2.6	7	6	45
50	60.3	57	165	125	18	4	M16	18	74	74	2.9	8	5	45
65	76.1	65	185	145	18	8	M16	18	92	92	2.9	10	6	45
80	88.9	89	200	160	18	8	M16	20	105	105	3.2	10	6	50
100	114.3	108	220	180	18	8	M16	20	131	131	3.6	12	8	52
125	139.7	133	250	210	18	8	M16	22	156	156	4	12	8	55
150	168.3	159	285	240	22	8	M20	22	184	184	4.5	12	10	55
200	219.1	219	340	295	22	8	M20	24	234	234	6.3	16	10	62
250	273	273	395	350	22	12	M20	26	292	292	6.3	16	12	68
300	323.9	325	445	400	22	12	M20	26	342	342	7.1	16	12	68
350	355.6	377	505	460	22	16	M20	26	385	402	7.1	16	12	68
400	406.4	426	565	515	26	16	M24	26	440	458	7.1	16	12	72
450	457	480	615	565	26	20	M24	28	488	510	7.1	16	12	72
500	508	530	670	620	26	20	M24	28	542	562	7.1	16	12	75
600	610	630	780	725	30	20	M27	28	642	660	7.1	18	12	80
700	711	720	895	840	30	24	M27	30	746	755	8	18	12	80
800	813	820	1015	950	33	24	M30	32	850	855	8	18	12	90
900	914	920	1115	1050	33	28	M30	34	950	954	10	20	12	95
1000	1016	1020	1230	1160	36	28	M33	34	1052	1054	10	20	16	95
1200	1219	1220	1455	1380	39	32	M36X3	38	1256	1256	11	25	16	115
1400	1422	1420	1675	1590	42	36	M39X3	42	1460	1460	12	25	16	120
1600	1626	1620	1915	1820	48	40	M45X3	46	1666	1666	14	25	16	130
1800	1829	1820	2115	2020	48	44	M45X3	50	1868	1866	15	30	16	140
2000	2032	2020	2325	2230	48	48	M45X3	54	2072	2070	16	30	16	150

HG/T20595-2009 (WN)

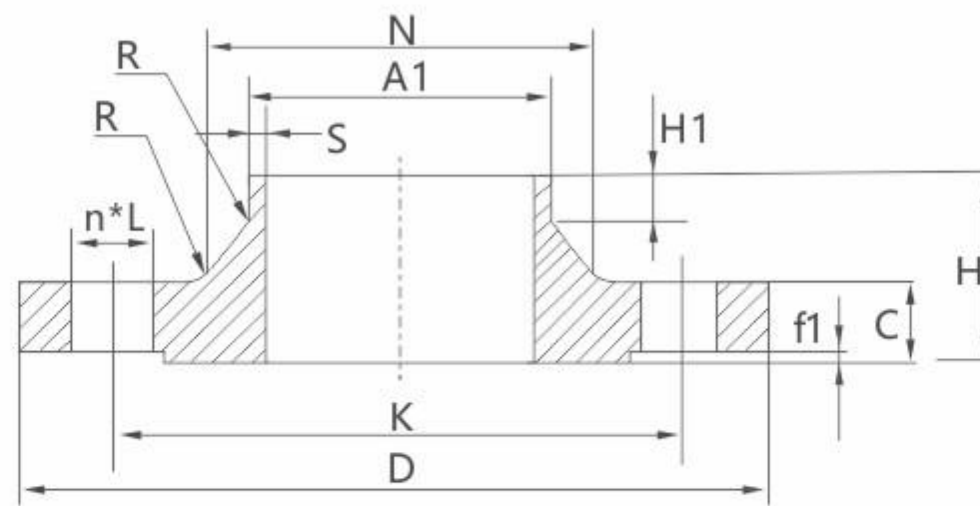
BUTT WELDING STEEL PIPE FLANGE WITH NECK

PN16

size	Steel pipe outer diameter A1		Connection size					Flange thickness	Flange neck				Flange height	
	DN	A	B	D	K	L	n		Th	C	A	B		S ≥
10	17.2	14	90	60	14	4	M12	16	28	28	1.8	6	4	35
15	21.3	18	95	65	14	4	M12	16	32	32	2.0	6	4	38
20	26.9	25	105	75	14	4	M12	18	40	40	2.3	6	4	40
25	33.7	32	115	85	14	4	M12	18	46	46	2.6	6	4	40
32	42.4	38	140	100	18	4	M16	18	56	56	2.6	6	6	42
40	48.3	45	150	110	18	4	M16	18	64	64	2.6	7	6	45
50	60.3	57	165	125	18	4	M16	18	74	74	2.9	8	5	45
65	76.1	65	185	145	18	8	M16	18	92	92	2.9	10	6	45
80	88.9	89	200	160	18	8	M16	20	105	105	3.2	10	6	50
100	114.3	108	220	180	18	8	M16	20	131	131	3.6	12	8	52
125	139.7	133	250	210	18	8	M16	22	156	156	4.0	12	8	55
150	168.3	159	285	240	22	8	M20	22	184	184	4.5	12	10	55
200	219.1	219	340	295	22	12	M20	24	235	235	6.3	16	10	62
250	273	273	405	355	26	12	M24	26	292	292	6.3	16	12	70
300	323.9	325	460	410	26	12	M24	28	344	344	7.1	16	12	78
350	355.6	377	520	470	26	16	M24	30	390	410	8.0	16	12	82
400	406.4	426	580	525	30	16	M27	32	445	464	8.0	16	12	85
450	457	480	640	585	30	20	M27	40	490	512	8.0	16	12	87
500	508	530	715	650	33	20	M30	44	548	578	8.0	16	12	90
600	610	630	840	770	36	20	M33	54	652	670	8.8	18	12	95
700	711	720	910	840	36	24	M33	36	755	759	8.8	18	12	100
800	813	820	1025	950	39	24	M36X3	38	855	855	10.0	20	12	105
900	914	920	1125	1050	39	28	M36X3	40	955	954	10.0	20	12	110
1000	1016	1020	1255	1170	42	28	M39X3	42	1058	1060	10.0	22	16	120
1200	1219	1220	1485	1390	48	32	M45X3	48	1262	1260	12.5	30	16	130
1400	1422	1420	1685	1590	48	36	M45X3	52	1465	1465	14.2	30	16	145
1600	1626	1620	1930	1820	56	40	M52X4	58	1668	1668	16	35	16	160
1800	1829	1820	2130	2020	56	44	M52X4	62	1870	1870	17.5	35	16	170
2000	2032	2020	2345	2230	62	48	M56X4	66	2072	2072	20	40	16	180

HG/T20595-2009 (WN)

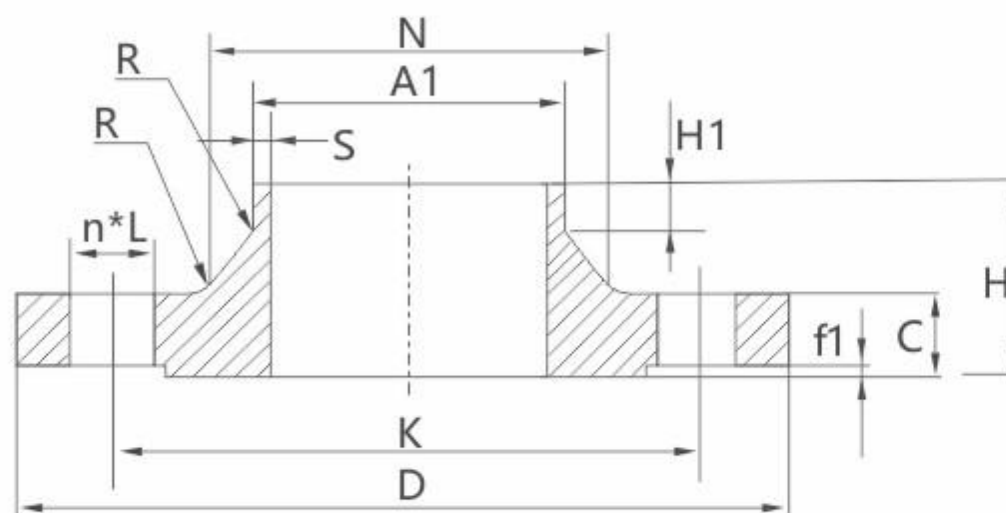
BUTT WELDING STEEL PIPE FLANGE WITH NECK



PN25

size	Steel pipe outer diameter A1		Connection size					Flange thickness	Flange neck				Flange height	
	DN	A	B	D	K	L	n		Th	C	A	B		S ≥
10	17.2	14	90	60	14	4	M12	16	28	28	1.8	6	4	35
15	21.3	18	95	65	14	4	M12	16	32	32	2.0	6	4	38
20	26.9	25	105	75	14	4	M12	18	40	40	2.3	6	4	40
25	33.7	32	115	85	14	4	M12	18	46	46	2.6	6	4	40
32	42.4	38	140	100	18	4	M16	18	56	56	2.6	6	6	42
40	48.3	45	150	110	18	4	M16	18	64	64	2.6	7	6	45
50	60.3	57	165	125	18	4	M16	20	75	75	2.9	8	6	48
65	76.1	76	185	145	18	8	M16	22	90	90	2.9	10	6	52
80	88.9	89	200	160	18	8	M16	24	105	105	3.2	12	8	58
100	114.3	108	235	190	22	8	M20	24	134	134	3.6	12	8	65
125	139.7	133	270	220	26	8	M24	26	162	162	4.0	12	8	68
150	168.3	159	300	250	26	8	M24	28	192	190	4.5	12	10	75
200	219.1	219	360	310	26	12	M24	30	244	244	6.3	16	10	80
250	273	273	425	370	30	12	M27	32	298	298	7.1	18	12	88
300	323.9	325	485	430	30	16	M27	34	352	352	8.0	18	12	92
350	355.6	377	555	490	33	16	M30	38	398	420	8.0	20	12	100
400	406.4	426	620	550	36	16	M33	40	452	472	8.8	20	12	110
450	457	480	670	600	36	20	M33	46	500	522	8.8	20	12	110
500	508	530	730	660	36	20	M33	48	558	580	10	20	12	125
600	610	630	845	770	39	20	M36X3	58	660	680	11	20	12	125

HG/T20595-2009 (WN)

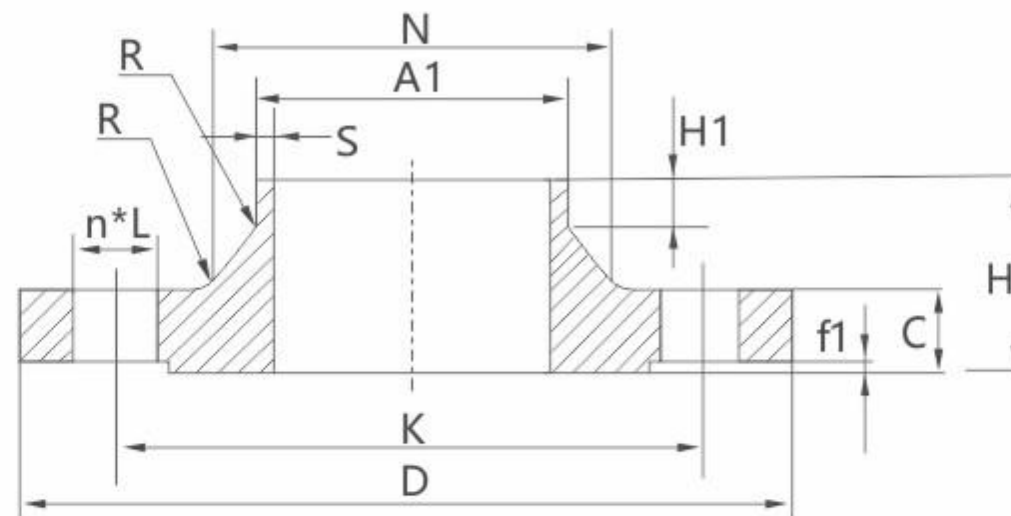
BUTT WELDING STEEL PIPE FLANGE WITH NECK

PN40

size	Steel pipe outer diameter A1		Connection size					Flange thickness	Flange neck				Flange height	
	DN	A	B	D	K	L	n		Th	C	A	B		S ≥
10	17.2	14	90	60	14	4	M12	16	28	28	1.8	6	4	35
15	21.3	18	95	65	14	4	M12	16	32	32	2.0	6	4	38
20	26.9	25	105	75	14	4	M12	18	40	40	2.3	6	4	40
25	33.7	32	115	85	14	4	M12	18	46	46	2.6	6	4	40
32	42.4	38	140	100	18	4	M16	18	56	56	2.6	6	6	42
40	48.3	45	150	110	18	4	M16	18	64	64	2.6	7	6	45
50	60.3	57	165	125	18	4	M16	20	75	75	2.9	8	6	48
65	76.1	76	185	145	18	8	M16	22	90	90	2.9	10	6	52
80	88.9	89	200	160	18	8	M16	24	105	105	3.2	12	8	58
100	114.3	108	235	190	22	8	M20	24	134	134	3.6	12	8	65
125	139.7	133	270	220	26	8	M24	26	162	162	4.0	12	8	68
150	168.3	159	300	250	26	8	M24	28	192	192	4.5	12	10	75
200	219.1	219	375	320	30	12	M27	34	244	244	6.3	16	10	88
250	273	273	450	385	33	12	M30	38	306	306	7.1	18	12	105
300	323.9	325	515	450	33	16	M30	42	362	362	8.0	18	12	115
350	355.6	377	580	510	36	16	M33	46	408	430	8.8	20	12	125
400	406.4	426	660	585	39	16	M36X3	50	462	482	11.0	20	12	135
450	457	480	685	610	39	20	M36X3	57	500	522	12.5	20	12	135
500	508	530	755	670	42	20	M39X3	57	562	584	14.2	20	12	140
600	610	630	890	795	48	20	M45X3	72	666	686	16.0	20	12	150

HG/T20595-2009 (WN)

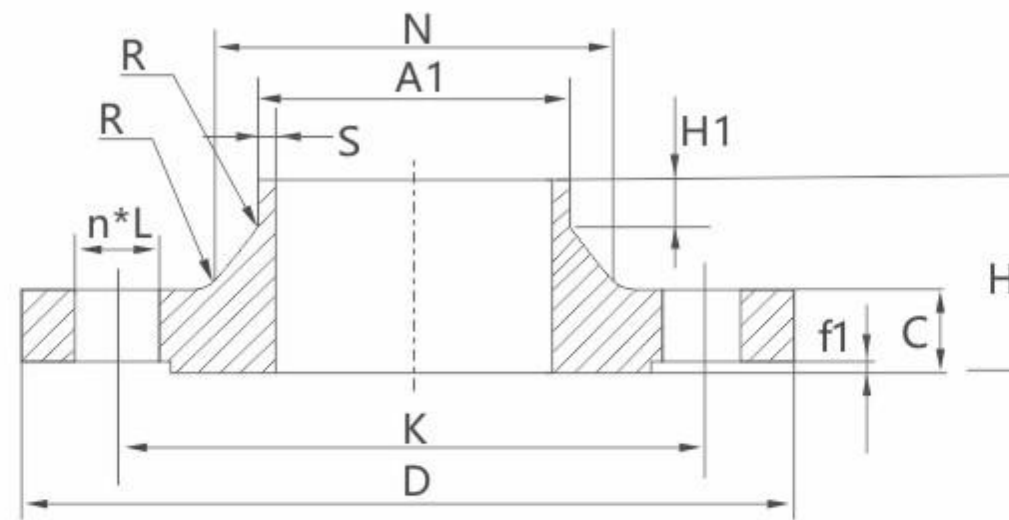
BUTT WELDING STEEL PIPE FLANGE WITH NECK



PN63

size	Steel pipe outer diameter A1		Connection size					Flange thickness	Flange neck				Flange height	
	DN	A	B	D	K	L	n		Th	C	A	B		S ≥
10	17.2	14	100	70	14	4	M12	20	32	32	1.8	6	4	45
15	21.3	18	105	75	14	4	M12	20	34	34	2.0	6	4	45
20	26.9	25	130	90	18	4	M16	22	42	42	2.6	8	4	48
25	33.7	32	140	100	18	4	M16	24	52	52	2.6	8	4	58
32	42.4	38	155	110	22	4	M20	24	62	62	2.9	8	6	60
40	48.3	45	170	125	22	4	M20	26	70	70	2.9	10	6	62
50	60.3	57	180	135	22	4	M20	26	82	82	2.9	10	6	62
65	76.1	76	205	160	22	8	M20	26	98	98	3.2	12	6	68
80	88.9	89	215	170	22	8	M20	28	112	112	3.6	12	8	72
100	114.3	108	250	200	26	8	M24	30	138	138	4.0	12	8	78
125	139.7	133	295	240	30	8	M27	34	168	168	4.5	12	8	88
150	168.3	159	345	280	33	8	M30	36	202	202	5.6	12	10	95
200	219.1	219	415	345	36	12	M33	42	256	256	7.1	16	10	110
250	273	273	470	400	36	12	M33	46	316	316	8.8	18	12	125
300	323.9	325	530	460	36	16	M33	52	372	372	11.0	18	12	140
350	355.6	377	600	525	39	16	M36X3	56	420	442	12.5	20	12	150
400	406.4	426	670	585	42	16	M39X3	60	475	495	14.2	20	12	160

HG/T20595-2009 (WN)

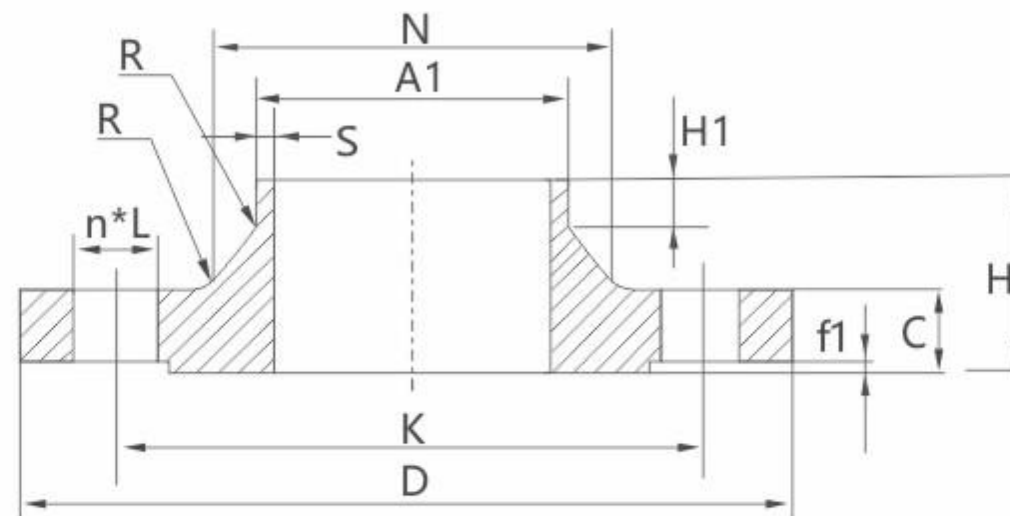
BUTT WELDING STEEL PIPE FLANGE WITH NECK

PN100

size	Steel pipe outer diameter A1		Connection size					Flange thickness	Flange neck				Flange height	
	DN	A	B	D	K	L	n		Th	C	A	B		S ≥
10	17.2	14	100	70	14	4	M12	20	32	32	1.8	6	4	45
15	21.3	18	105	75	14	4	M12	20	34	34	2.0	6	4	45
20	26.9	25	130	90	18	4	M16	22	42	42	2.6	8	4	48
25	33.7	32	140	100	18	4	M16	24	52	52	2.6	8	4	58
32	42.4	38	155	110	22	4	M20	24	62	62	2.9	8	6	60
40	48.3	45	170	125	22	4	M20	26	70	70	2.9	10	6	62
50	60.3	57	195	145	26	4	M24	28	90	90	3.2	10	6	68
65	76.1	76	220	170	26	8	M24	30	108	108	3.6	12	6	76
80	88.9	89	230	180	26	8	M24	32	120	120	4.0	12	8	78
100	114.3	108	265	210	30	8	M27	36	150	150	5.0	12	8	90
125	139.7	133	315	250	33	8	M30	40	180	180	6.3	12	8	105
150	168.3	159	355	290	33	12	M30	44	210	210	7.1	12	10	115
200	219.1	219	430	360	36	12	M33	52	278	278	10.0	16	10	130
250	273	273	505	430	39	12	M36X3	60	340	340	12.5	18	12	157
300	323.9	325	585	500	42	16	M39X3	68	400	400	14.2	18	12	170
350	355.6	377	655	560	48	16	M45X3	74	460	482	16.0	20	12	189

HG/T20595-2009 (WN)

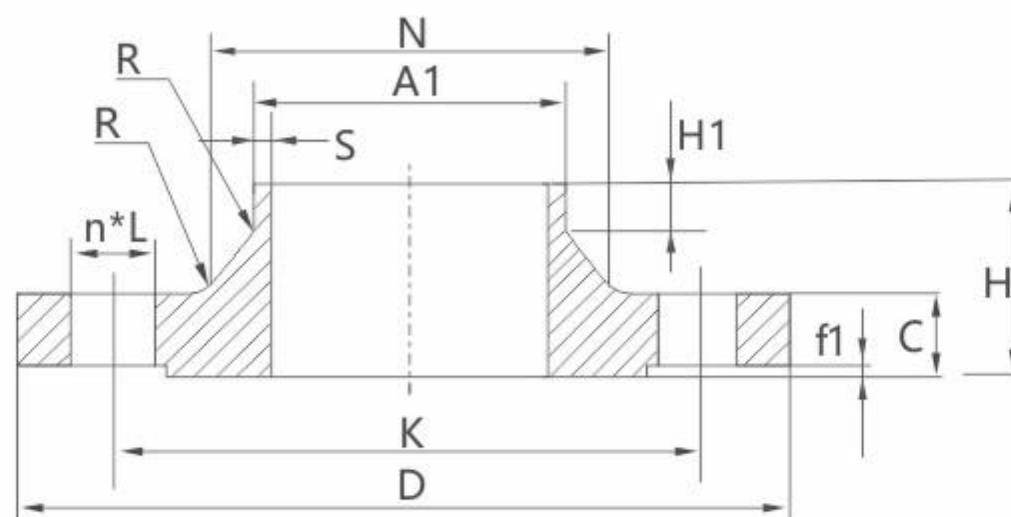
BUTT WELDING STEEL PIPE FLANGE WITH NECK



PN160

size	Steel pipe outer diameter A1		Connection size					Flange thickness	Flange neck				Flange height	
	DN	A	B	D	K	L	n		Th	C	A	B		S ≥
10	17.2	14	100	70	14	4	M12	20	32	32	2.0	6	4	45
15	21.3	18	105	75	14	4	M12	20	34	34	2.0	6	4	45
20	26.9	25	130	90	18	4	M16	24	42	42	2.9	6	4	52
25	33.7	32	140	100	18	4	M16	24	52	52	2.9	8	4	58
32	42.4	38	155	110	22	4	M20	28	60	60	3.6	8	5	60
40	48.3	45	170	125	22	4	M20	28	70	70	3.6	10	6	64
50	60.3	57	195	145	26	4	M24	30	90	90	4	10	6	75
65	76.1	76	220	170	26	8	M24	34	108	108	5	12	6	82
80	88.9	89	230	180	26	8	M24	36	120	120	6.3	12	8	86
100	114.3	108	265	210	30	8	M27	40	150	150	8	12	8	100
125	139.7	133	315	250	33	8	M30	44	180	180	10	14	8	115
150	168.3	159	355	290	33	12	M30	50	210	210	12.5	14	10	128
200	219.1	219	430	360	36	12	M33	60	278	278	16	16	10	140
250	273	273	515	430	42	12	M39X3	68	340	340	20	18	12	155
300	323.9	325	585	500	42	16	M39X3	78	400	400	22.2	18	12	175

HG/T20597-2009 (SW)

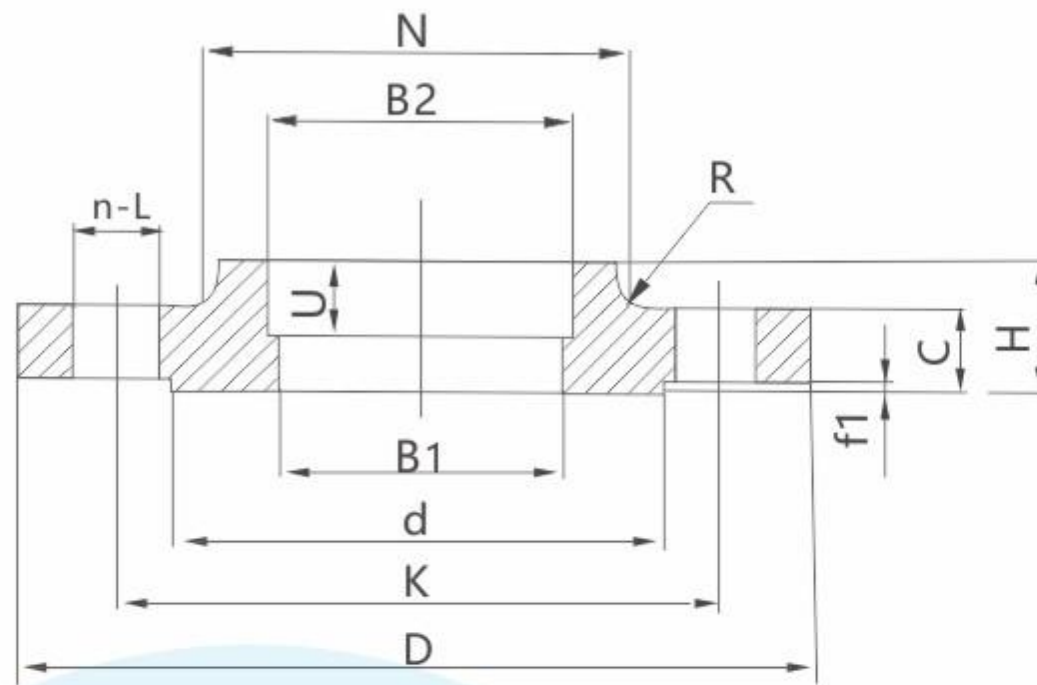
SOCKET WELDED STEEL PIPE FLANGE

PN10

(mm)

size	Outer diameter of steel pipe A1		Flange outside diameter	Connection size				Francois thickness	Flange bore B1		Socket jack			Flange neck		H
				K	L	n	Th		C	A	B	B2		U	N	
DN	A	B	D					K				L	n			Th
10	17.2	14	90	60	14	4	M12	16	11.5	9	18	15	9	30	4	22
15	21.3	18	95	65	14	4	M12	16	15.5	12	22.5	19	10	35	4	22
20	26.9	25	105	75	14	4	M12	18	21	19	27.5	26	11	45	4	26
25	33.7	32	115	85	14	4	M12	18	27	26	34.5	33	13	52	4	28
32	42.5	38	140	100	18	4	M16	18	35	30	43.5	39	14	60	6	30
40	48.3	45	150	110	18	4	M16	18	41	37	49.5	46	16	70	6	32
50	60.3	57	165	125	18	4	M16	18	52	49	61.5	59	17	84	5	28

PN16

(mm)

10	17.2	14	90	60	14	4	M12	16	11.5	9	18	15	9	30	4	22
15	21.3	18	95	65	14	4	M12	16	15.5	12	22.5	19	10	35	4	22
20	26.9	25	105	75	14	4	M12	18	21	19	27.5	26	11	45	4	26
25	33.7	32	115	85	14	4	M12	18	27	26	34.5	33	13	52	4	28
32	42.5	38	140	100	18	4	M16	18	35	30	43.5	39	14	60	6	30
40	48.3	45	150	110	18	4	M16	18	41	37	49.5	46	16	70	6	32
50	60.3	57	165	125	18	4	M16	18	52	49	61.5	59	17	84	5	28

PN25

size	Outer diameter of steel pipe A1		Flange outside diameter	Connection size				Francois thickness	Flange bore B1		Socket jack			Flange neck		H
				K	L	n	Th		B2		U	N	R			
	DN	A	B					D	C	A				B	A	
10	17.2	14	90	60	14	4	M12	16	11.5	9	18	15	9	30	4	22
15	21.3	18	95	65	14	4	M12	16	15.5	12	22.5	19	10	35	4	22
20	26.9	25	105	75	14	4	M12	18	21	19	27.5	26	11	45	4	26
25	33.7	32	115	85	14	4	M12	18	27	26	34.5	33	13	52	4	28
32	42.5	38	140	100	18	4	M16	18	35	30	43.5	39	14	60	6	30
40	48.3	45	150	110	18	4	M16	18	41	37	49.5	46	16	70	6	32
50	60.3	57	165	125	18	4	M16	20	52	49	61.5	59	17	84	6	34

PN40

10	17.2	14	90	60	14	4	M12	16	11.5	9	18	15	9	30	4	22
15	21.3	18	95	65	14	4	M12	16	15.5	12	22.5	19	10	35	4	22
20	26.9	25	105	75	14	4	M12	18	21	19	27.5	26	11	45	4	26
25	33.7	32	115	85	14	4	M12	18	27	26	34.5	33	13	52	4	28
32	42.5	38	140	100	18	4	M16	18	35	30	43.5	39	14	60	6	30
40	48.3	45	150	110	18	4	M16	18	41	37	49.5	46	16	70	6	32
50	60.3	57	165	125	18	4	M16	20	52	49	61.5	59	17	84	6	34

PN63

10	17.2	14	100	70	14	4	M12	20	11.5	9	18	15	9	40	4	28
15	21.3	18	105	75	14	4	M12	20	15.5	12	22.5	19	10	43	4	28
20	26.9	25	130	90	18	4	M16	22	21	19	27.5	26	11	52	4	30
25	33.7	32	140	100	18	4	M19	24	27	26	34.5	33	13	60	4	32
32	42.5	38	155	110	22	4	M20	24	35	30	43.5	39	14	68	6	32
40	48.3	45	170	125	22	4	M20	26	41	37	49.5	46	16	80	6	34
50	60.3	57	180	135	22	4	M20	26	52	49	61.5	59	17	90	6	36

PN100

10	17.2	14	100	70	14	4	M12	20	11.5	9	18	15	9	40	4	28
15	21.3	18	105	75	14	4	M12	20	15.5	12	22.5	19	10	43	4	28
20	26.9	25	130	90	18	4	M16	22	21	19	27.5	26	11	52	4	30
25	33.7	32	140	100	18	4	M16	24	27	26	34.5	33	13	60	4	32
32	42.5	38	155	110	22	4	M20	24	35	30	43.5	39	14	68	6	32
40	48.3	45	170	125	22	4	M20	26	41	37	49.5	46	16	80	6	34
50	60.3	57	195	145	26	4	M24	28	52	49	61.5	59	17	95	6	36

HG/T20598-2009(Th)

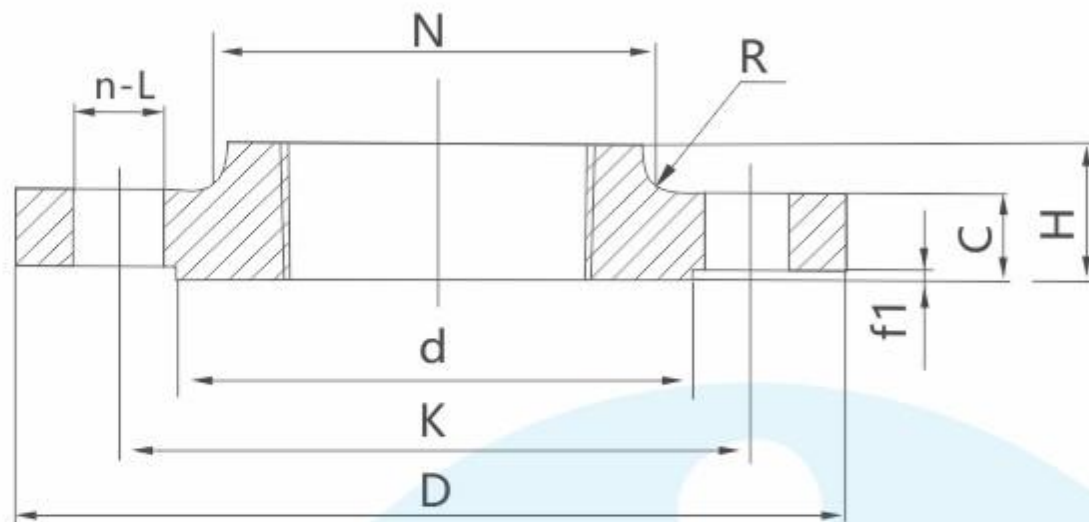
PIPE FLANGE MADE OF REBAR

PN6

(mm)

size	Outer diameter of steel pipe A1	Flange outside diameter	Connection size				Flange thickness	Flange neck		H	Pipe thread specification Rc, Rp or NPT(in)
			K	L	n	Th		C	R		
DN	A	D	K	L	n	Th	C	N	R	H	Pipe thread specification Rc, Rp or NPT(in)
10	17.2	75	50	11	4	M10	12	25	4	20	3/8
15	21.3	80	55	11	4	M10	12	30	4	20	1/2
20	26.9	90	65	11	4	M10	14	40	4	24	3/4
25	33.7	100	75	11	4	M10	14	50	4	24	1
32	42.4	120	90	14	4	M12	14	60	6	26	1 1/4
40	48.3	130	100	14	4	M12	14	70	6	26	1 1/2
50	60.3	140	110	14	4	M12	14	80	6	28	2
65	76.1	160	130	14	4	M12	14	100	6	32	2 1/2
80	88.9	190	150	18	4	M16	16	110	8	34	3
100	114.3	210	170	18	4	M16	16	130	8	40	4
125	139.7	240	200	18	8	M16	18	160	8	44	5
150	168.3	265	225	18	8	M16	18	185	10	44	6

PN10

size	Outer diameter of steel pipe A1	Flange outside diameter	Connection size				Flange thickness	Flange neck		H	Pipe thread specification Rc, Rp or NPT(in)
			K	L	n	Th		C	N		
DN	A	D									
10	17.2	90	60	14	4	M12	16	30	4	22	3/8
15	21.3	95	65	14	4	M12	16	35	4	22	1/2
20	26.9	105	75	14	4	M12	18	45	4	26	3/4
25	33.7	115	85	14	4	M12	18	52	4	28	1
32	42.4	140	100	18	4	M16	18	60	6	30	1 1/4
40	48.3	150	110	18	4	M16	18	70	6	32	1 1/2
50	60.3	165	125	18	4	M16	18	84	6	28	2
65	76.1	185	145	18	8	M16	18	104	6	32	2 1/2
80	88.9	200	160	18	8	M16	20	118	6	34	3
100	114.3	220	180	18	8	M16	20	140	8	40	4
125	169.7	250	210	18	8	M16	22	168	8	44	5
150	168.3	285	240	22	8	M20	22	195	10	44	6

PN16

size	Outer diameter of steel pipe A1	Flange outside diameter	Connection size				Flange thickness	Flange neck		H	Pipe thread specification Rc, Rp or NPT(in)
			K	L	n	Th		C	N		
DN	A	D									
10	17.2	90	60	14	4	M12	16	30	4	22	3/8
15	21.3	95	65	14	4	M12	16	35	4	22	1/2
20	26.9	105	75	14	4	M12	18	45	4	26	3/4
25	33.7	115	85	14	4	M12	18	52	4	28	1
32	42.4	140	100	18	4	M16	18	60	6	30	1 1/4
40	48.3	150	110	18	4	M16	18	70	6	32	1 1/2
50	60.3	165	125	18	4	M16	18	84	5	28	2
65	76.1	185	145	18	8	M16	18	104	6	32	2 1/2
80	88.9	200	160	18	8	M16	20	118	6	34	3
100	114.3	220	180	18	8	M16	20	140	8	40	4
125	169.7	250	210	18	8	M16	22	168	8	44	5
150	168.3	285	240	22	8	M20	22	195	10	44	6

PN25

(mm)

size	Outer diameter of steel pipe A1	Flange outside diameter	Connection size				Flange thickness	Flange neck		H	Pipe thread specification Rc, Rp or NPT(in)
			K	L	n	Th		C	N		
DN	A	D									
10	17.2	90	60	14	4	M12	16	30	4	22	3/8
15	21.3	95	65	14	4	M12	16	35	4	22	1/2
20	26.9	105	75	14	4	M12	18	45	4	26	3/4
25	33.7	115	85	14	4	M12	18	52	4	28	1
32	42.4	140	100	18	4	M16	18	60	6	30	1 1/4
40	48.3	150	110	18	4	M16	18	70	6	32	1 1/2
50	60.3	165	125	18	4	M16	20	84	6	34	2
65	76.1	185	145	18	8	M16	22	104	6	38	2 1/2
80	88.9	200	160	18	8	M16	24	118	8	40	3
100	114.3	235	190	22	8	M20	24	145	8	44	4
125	169.7	270	220	26	8	M24	26	170	8	48	5
150	168.3	300	250	26	8	M24	28	200	10	52	6

PN40

size	Outer diameter of steel pipe A1	Flange outside diameter	Connection size				Flange thickness	Flange neck		H	Pipe thread specification Rc, Rp or NPT(in)
			K	L	n	Th		C	N		
DN	A	D									
10	17.2	90	60	14	4	M12	16	30	4	22	3/8
15	21.3	95	65	14	4	M12	16	35	4	22	1/2
20	26.9	105	75	14	4	M12	18	45	4	26	3/4
25	33.7	115	85	14	4	M12	18	52	4	28	1
32	42.4	140	100	18	4	M16	18	60	6	30	1 1/4
40	48.3	150	110	18	4	M16	18	70	6	32	1 1/2
50	60.3	165	125	18	4	M16	20	84	6	34	2
65	76.1	185	145	18	8	M16	22	104	6	38	2 1/2
80	88.9	200	160	18	8	M16	24	118	8	40	3
100	114.3	235	190	22	8	M20	24	145	8	44	4
125	169.7	270	220	26	8	M24	26	170	8	48	5
150	168.3	300	250	26	8	M24	28	200	10	52	6

HG/T20599-2009 (PJ/SE)

BUTT WELD RING LOOSE SLEEVE STEEL PIPE FLANGE

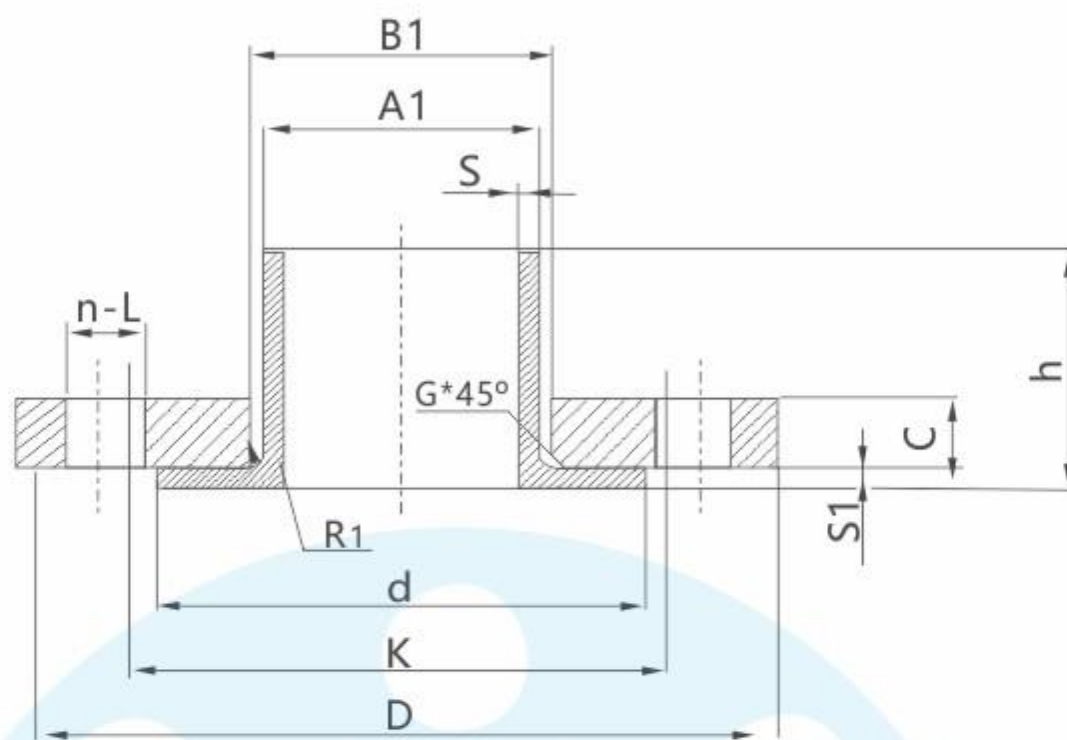

PN6

(mm)

size	A1		Flange outside diameter	Connection size				Flange thickness	Flange bore B1		R1	G	Butt-welded ring			
	DN	A		B	D	K	L		n	Th			C	A	B	H
10	17.2	14	75	50	11	4	M10	12	21	18	3	3	28	35	1.8	1.8
15	21.3	18	80	55	11	4	M10	12	25	22	3	3	30	40	2.0	2.0
20	26.9	25	90	65	11	4	M10	14	31	29	4	4	32	50	2.3	2.3
25	33.7	32	100	75	11	4	M10	14	38	36	4	4	35	60	2.6	2.6
32	42.4	38	120	90	14	4	M12	16	46	42	5	5	35	70	2.6	2.6
40	48.3	45	130	100	14	4	M12	16	53	50	5	5	38	80	2.6	2.6
50	60.3	57	140	110	14	4	M12	16	65	62	5	5	38	90	2.9	2.9
65	76.1	76	160	130	14	4	M12	16	81	81	6	6	38	110	2.9	2.9
80	88.9	89	190	150	18	4	M16	18	94	94	6	6	42	128	3.2	3.2
100	114.3	108	210	170	18	4	M16	18	120	114	6	6	45	148	3.6	3.6
125	139.7	133	240	200	18	8	M16	20	145	139	6	6	48	178	4.0	4.0
150	168.3	159	265	225	18	8	M16	20	174	165	6	6	48	202	4.5	4.5
200	219.1	219	320	280	18	8	M16	22	226	226	6	6	55	258	6.3	6.3
250	273	273	375	335	18	12	M16	24	281	281	8	8	60	312	6.3	6.3
300	323.9	325	440	395	22	12	M20	24	333	334	8	8	62	365	7.1	7.1
350	355.6	377	490	445	22	12	M20	26	365	386	8	8	62	415	7.1	7.1
400	406.4	426	540	495	22	16	M20	28	416	435	8	8	65	465	7.1	7.1
450	457	480	595	550	22	16	M20	30	467	490	8	8	65	520	7.1	7.1
500	508	530	645	600	22	20	M20	30	519	541	8	8	68	570	7.1	7.1
600	610	630	755	705	26	20	M24	32	622	642	8	8	70	670	7.1	7.1

PN10对焊环松套钢制管法兰

(mm)

size	A1		Flange outside diameter	Connection size				Flange thickness	Flange bore B1		R1	G	Butt-welded ring			
				K	L	n	Th		A	B			H	d	S	S1
DN	A	B	D					C	A	B						
10	17.2	14	90	60	14	4	M12	14	21	18	3	3	35	40	1.8	1.8
15	21.3	18	95	65	14	4	M12	14	25	22	3	3	38	45	2.0	2.0
20	26.9	25	105	75	14	4	M12	16	31	29	4	4	40	58	2.3	2.3
25	33.7	32	115	85	14	4	M12	16	38	36	4	4	40	68	2.6	2.6
32	42.4	38	140	100	18	4	M16	18	47	42	5	5	42	78	2.6	2.6
40	48.3	45	150	110	18	4	M16	18	53	50	5	5	45	88	2.6	2.6
50	60.3	57	165	125	18	4	M16	19	65	62	5	5	45	102	2.9	2.9
65	76.1	76	185	145	18	8	M16	20	81	81	6	6	45	122	2.9	2.9
80	88.9	89	200	160	18	8	M16	20	94	94	6	6	50	138	3.2	3.2
100	114.3	108	220	180	18	8	M16	22	120	114	6	6	52	158	3.6	3.6
125	139.7	133	250	210	18	8	M16	22	145	139	6	6	55	188	4.0	4.0
150	168.3	159	285	240	22	8	M20	24	174	165	6	6	55	212	4.5	4.5
200	219.1	219	340	295	22	8	M20	24	226	226	6	6	62	268	6.3	6.3
250	273	273	395	350	22	12	M20	24	281	281	8	8	68	320	6.3	6.3
300	323.9	325	445	400	22	12	M20	26	333	334	8	8	68	370	7.1	7.1
350	355.6	377	505	460	22	16	M20	28	365	386	8	8	68	430	7.1	7.1
400	406.4	426	565	515	26	16	M24	32	416	435	8	8	72	482	7.1	7.1
450	457	480	615	565	26	20	M24	36	467	490	8	8	72	532	7.1	7.1
500	508	530	670	620	26	20	M24	38	519	541	8	8	75	585	7.1	7.1
600	610	630	780	725	30	20	M27	42	622	642	8	8	80	685	7.1	7.1

PN16对焊环松套钢制管法兰

(mm)

size	A1		Flange outside diameter	Connection size				Flange thickness	Flange bore B1		R1	G	Butt-welded ring			
				K	L	n	Th		A	B			H	d	S	S1
DN	A	B	D					C	A	B						
10	17.2	14	90	60	14	4	M12	14	21	18	3	3	35	40	1.8	1.8
15	21.3	18	95	65	14	4	M12	14	25	22	3	3	38	45	2.0	2.0
20	26.9	25	105	75	14	4	M12	16	31	29	4	4	40	58	2.3	2.3
25	33.7	32	115	85	14	4	M12	16	38	36	4	4	40	68	2.6	2.6
32	42.4	38	140	100	18	4	M16	18	47	42	5	5	42	78	2.6	2.6
40	48.3	45	150	110	18	4	M16	18	53	50	5	5	45	88	2.6	2.6
50	60.3	57	165	125	18	4	M16	19	65	62	5	5	45	102	2.9	2.9
65	76.1	76	185	145	18	8	M16	20	81	81	6	6	45	122	2.9	2.9
80	88.9	89	200	160	18	8	M16	20	94	94	6	6	50	138	3.2	3.2
100	114.3	108	220	180	18	8	M16	22	120	114	6	6	52	158	3.6	3.6
125	139.7	133	250	210	22	8	M16	22	145	139	6	6	55	188	4.0	4.0
150	168.3	159	285	240	22	8	M20	24	174	165	6	6	55	212	4.5	4.5
200	219.1	219	340	295	26	12	M20	26	226	226	6	6	62	268	6.3	6.3
250	273	273	405	355	26	12	M24	29	281	281	8	8	70	320	6.3	6.3
300	323.9	325	460	410	26	12	M24	32	333	334	8	8	78	378	7.1	7.1
350	355.6	377	520	470	30	16	M24	35	365	386	8	8	82	428	8.0	8.0
400	406.4	426	580	525	30	16	M27	38	416	435	8	8	85	490	8.0	8.0
450	457	480	640	585	33	20	M27	42	467	490	8	8	87	550	8.0	8.0
500	508	530	715	650	33	20	M30	46	519	541	8	8	90	610	8.0	8.0
600	610	630	840	770	36	20	M30	52	622	642	8	8	95	725	8.8	8.8

